

Power and Propulsion Options for the Modern warship

David J Bricknell: Director Systems, Rolls-Royce Naval Marine, UK

Richard Partridge: Propulsion System Manager, New Projects, Rolls-Royce Naval Marine, UK

Modern naval combatants broadly divide into three ship types: ocean capable patrol-craft, globally deployable combatants, and the developing new class of fast littoral combatant. Each ship type places different and significant demands on the power and propulsion system. This paper describes the technical and operational issues driving the demands on the power and propulsion system including ship speed, un-refuelled endurance, fuel type, on-board maintenance and the new electric mission-systems.

KEY WORDS

Global; Combatant; Fast; Ocean-Capable; Littoral
Gas-Turbine; Waterjet

INTRODUCTION

The **globally deployable combatant** is a 'blue-water' capable ship operating throughout the world's oceans. It provides area air defence with large numbers of Vertically Launched (VL) missiles, large multi-function radar, and gunfire support. It carries special-forces, one or two medium/large helicopters, and deploys Anti-Submarine Warfare (ASW) assets through unmanned vehicles. The role of the ship requires it to have a long un-refuelled endurance together with a good sustained speed for accompanying carrier battle groups. This requires the capability to loiter for prolonged periods and also have a good sprint speed. The modern ship still has a substantial complement (about 200, reduced from the more usual 350 or so from a generation ago) and spends a considerable time away from base port, requiring systems and equipment to be reliable and maintainable with or without an accompanying infrastructure.

Current and future ships fulfilling this requirement are normally around 6,000 - 9,000t (in a conventional displacement-type hull) with a power and propulsion system driving twin propellers for a ship speed in the range of 28 to 32 knots. Examples of ships in this class are the European Type 45, LCF, F124, F125, F100 and FREMM up to the larger faster US DDG51, Japan's Kongo and South Korea's KDXIII. It is no surprise, perhaps, that many of the designs arose from the nine-nation NATO NFR90 programme.

The **Ocean Capable Patrol Craft (OCPC)** is a 'green-water' vessel patrolling near to the base country with capability to operate off the continental shelf, out to around 1000nm or so from the shoreline. Current ships fulfilling this role are around 1,500t/90m Offshore Patrol Vessel (OPV), or Corvette, with minimal crew number (~60 complement) and a shorter un-refuelled endurance of about 2,500nm at 12-15 knots. The OCPC is generally a more complex and capable ship than a purely Exclusive Economic Zone (EEZ) protection vessel and its role is more than just fisheries and minerals protection. The ships tend to be faster (22-26 knots) than the typical 20-knot EEZ OPV but slower than the Global Combatant. This class of vessel has tended to be all-diesel powered, primarily for initial cost reasons but also because speed aspirations are limited. At the upper end of the OCPC category, highly agile corvettes with overall lengths of up to 110m and top speeds approaching 30 knots require 12-15MW per shaft. This in theory can be developed using an all-diesel propulsion train but power density then starts to become a dominant factor. New developments in gas turbine and diesel combinations may offer attractive alternatives to traditional arrangements.

The developing new class of **fast combatant** currently focuses around broadly two types of craft: the first is the Swedish Visby-type own-littorals combatant, and the second is the trans-oceanic littoral combatant like the US Littoral Combat Ship. Both types of vessel are designed to operate close to shore either in one's own littorals or in those of another country. The third part of this paper looks at propulsion options for a putative 2,500t, >40kt fast combatant delivering high-speed, with shallow draft, and adopting waterjet propulsion, and gas turbine/diesel combinations.

GLOBAL COMBATANT

The globally deployable combatant needs long un-refuelled endurance and a good sprint speed both for coastline dominance and keeping up with large carrier battle group [1]. The ship will spend time throughout the speed range and will need flexibility in its power and propulsion system.

The Global Combatant's operational requirement will demand a fuel-efficient, high-power, low at-sea-maintenance/upkeep power and propulsion system and supporting equipments. Current and near-future designs for this class of ship are between 6,000t and 9,000t with speeds of 28 to 32 knots. Without exception the ships are twin propeller-driven and require an installed propulsive power of between 35MW to 80MW. Older designs have an un-refuelled range of about 4,000nm at 18 knots, whilst future requirements are for 6,000nm or more at a similar or greater speed. A ship's service and mission system electrical load of about 2-4 MWe is demanded once the ship is at sea and combat ready, driven by the large multi-function radar and the substantial accommodation requirement.

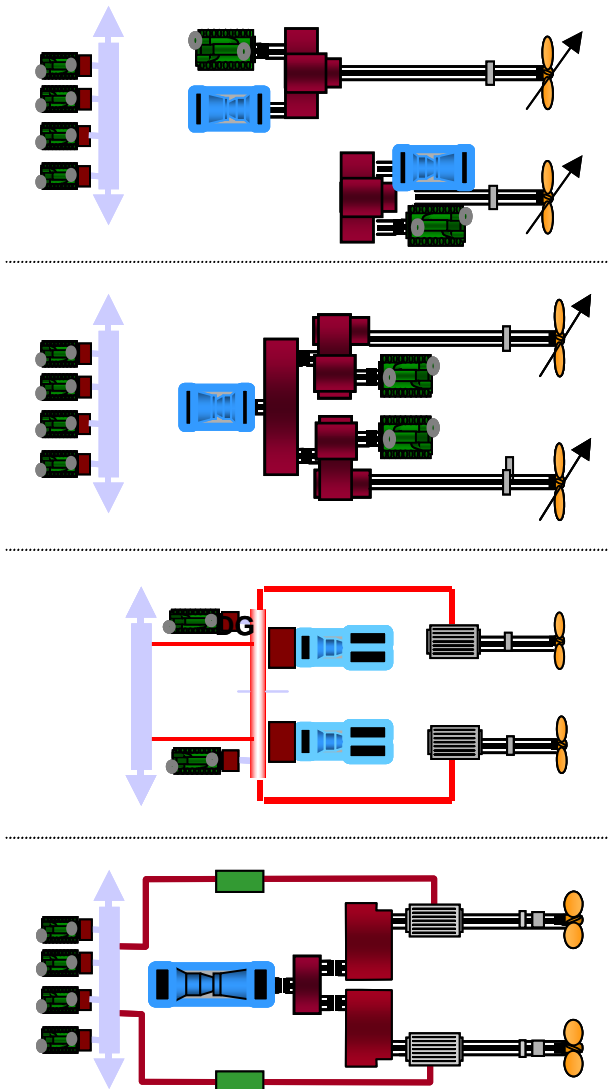

Figure 1 –Propulsion system options for 6,000t/28kt Global Combatant

With such a broad range of power required there is naturally a considerable diversity in configuration of the selected system. Single gas turbine CODOG, or CODAG, twin gas turbine CODOG or CODAG, all-electric, and hybrid electrical/mechanical systems are all in evidence. Major prime movers are selected from the LM2500 or Spey engines and from the newly introduced WR-21 and MT30 gas turbines. Medium-speed diesels, high-speed diesels, gas turbine alternators all contribute to the variety of systems. For comparison purposes two design points have been chosen: the first at 28 knots and 6,000t ~ 36MW, and the second 30+knots and 9,000t ~ 72MW: this propulsion power giving a representative figure for end-of-life ship's condition in Sea State 4.

Taking the smaller of the ships first, propulsion options include traditional twin gas turbine and diesel combinations, single gas turbine and diesel, all-electric and the new hybrid-electric systems. See figure 1 for configuration illustrations.

The twin gas turbine CODOG system has been a standard amongst most European and many worldwide navies for some time but in a bid to reduce initial acquisition costs has recently seen competition from single gas turbine CODAG/CODOG and hybrid -electric systems.

System	Fuel for 7000nm @ 18 knts	Annual Fuel Burnt	M/C Wt	M/Cwt inc fuel
Twin GT CODOG	853t	7840t	416t	1269t
Single GT CODOG	836t	7991t	388t	1224t
All-Electric	1028t	7758t	800t	1828t
Single GT CODLAG	729t	6964t	559t	1288t

Figure 2 – Summary characteristics of 6,000t combatant

All-electric has now been introduced into the UK Type 45 destroyer, delivering good endurance up to transit speeds with low on-board maintenance and a minimal number of prime-movers.

Comparisons of range, annual fuel burn (against a typical operational profile), machinery weight, and combined machinery and fuel weight for the 6,000t 28-knot ship can be seen in figure 2.

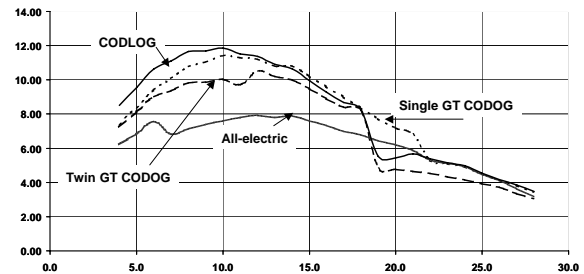

Figure 3 - Unrefuelled endurance by ship speed for the 6,000t combatant.

Maximum speed of all the ships is assumed the same, although the extra weight of the hybrid and particularly the all-electric systems will bring some displacement penalty. Annual fuel burn of the systems is similar across the two mechanical and the all-electric systems. The Hybrid-electric system adopts fuel-efficient medium-speed (720rpm) diesels giving increased range and lower annual fuel burn.

Un-refuelled endurance is shown in figure 3 throughout the ships operating speed range.

For the larger Destroyers, today's most commonly installed system adopts four medium power marine gas turbines coupled in a COGAG arrangement (total propulsion power of 72MW) supported by three small gas turbine alternators to provide electrical load (3x2.5MW). The system delivers low-at-sea maintenance by virtue of its all gas turbine prime-mover selection but it falls short in delivering long un-refuelled endurance or in providing any electrical power headroom for future adoption of electric mission systems.

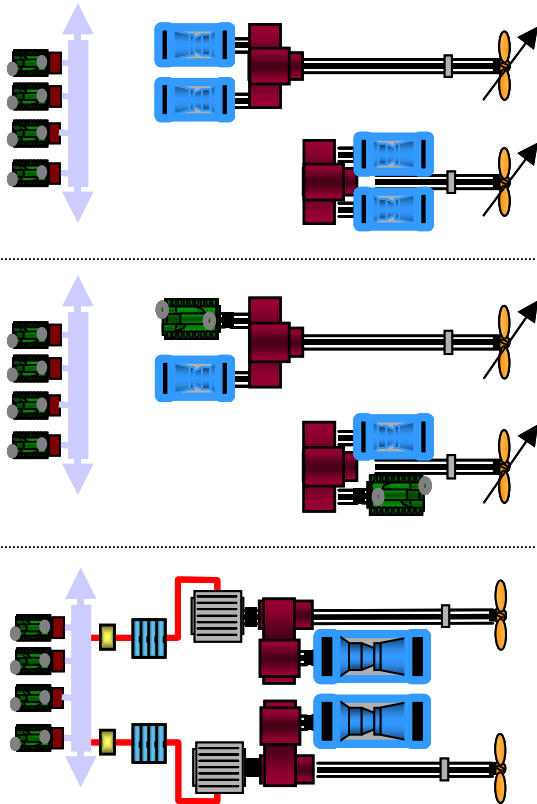

Figure 4 –Propulsion system options for 9000t/32kt Global Combatant

Comparisons of range, annual fuel burn, machinery weight and combined machinery and fuel weight for the 9,000t 32-knot ship can be seen in figure 5.

An all-electric power and propulsion is not included here as the power density required for the Global Combatant's 32 knots is more than one and a half times that currently being achieved by today's technology [2].

COGAG suffers from limited range but is a compact and lightweight system. Introducing two larger gas turbines to maintain the high maximum speed enables a fuel efficient

'cruise' system to be introduced either with two main propulsion diesels or by using a hybrid electric technology. Hybrid in particular brings very significant benefits for a combatant which is likely to operate for a considerable time at 6 – 10 knots using just a few hundred kilowatts of propulsion but have significant combat and hotel power requirements.

System	Fuel for 7000nm @ 18 knts	Annual Fuel Burnt	M/C Wt	M/C wt inc fuel
COGAG	1201t	10803t	351t	1553t
CODOG	799t	9086t	375t	1174t
CODLOG	707t	8876t	663t	1371t

Figure 5 – Summary characteristics of 9,000t combatant

As with the 6,000t example, the 9,000t hybrid can also adopt very fuel-efficient medium speed diesels to deliver excellent endurance and low annual fuel burn (figure 6), whilst incurring only minimal increase in machinery weight within a similar overall ship displacement.

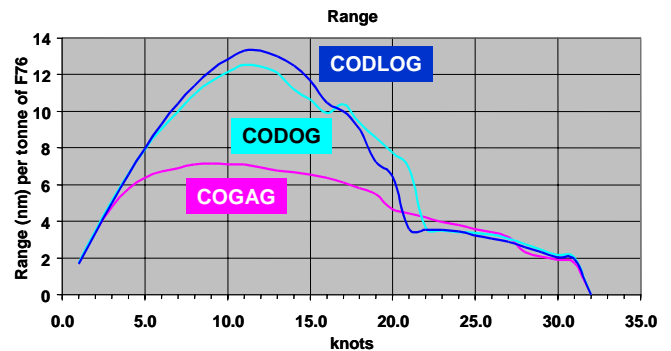

Figure 6 Unrefuelled endurance against ship speed for the 9,000t combatant.

OCEAN CAPABLE PATROL CRAFT

The Ocean Capable Patrol Craft (OCPC) extends littoral capability into 'local' green-water. Good sea-keeping and a powerful combat system are required but within a relatively compact and inexpensive platform with a limited complement. This has tended to lead to a new and very populous class of ship sometimes described as Corvettes (or even Frigates), but just as often described as Offshore Patrol Craft (OPVs), although they clearly have a role above and beyond protection of a country's

Exclusive Economic Zone (EEZ).

Currently this class of ship is designed at around 90m with a displacement of a little less than 2,000t and a maximum speed of about 22knots to maybe 26kts. Propulsion has in the past been a CODAD configuration where two high-speed sequentially turbocharged (12 or 16 cylinder) diesels are configured on each shaft. In this way a high maximum speed is achieved (all four engines running) whilst reducing to one engine running per shaft addresses the loiter speeds (6 – 8 knots) and patrol speeds of 10 to 20 knots. The complexity introduced with this system includes the ‘AND’ gearbox, synchronising and combining power from multiple diesels, the multiple diesel-mounted turbochargers and the complex control system necessary to cope with what is effectively a double-propeller law when operating on two engines rather than four (assumes a single speed gearbox). Figure 7 illustrates the issue.

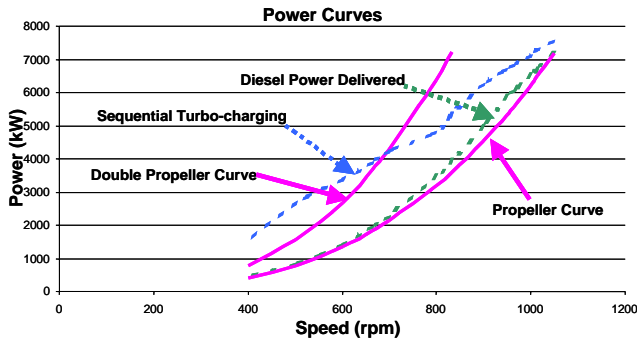

Figure 7 Sequential turbo-charging in a CODAD or a trail shaft configuration where, for a considerable part of the operational profile of the ship, the engine sees double-torque from the propeller.

Recent power increases in diesels have enabled a twin-engine arrangement (rather than four-engine CODAD) to be considered. High maximum speeds are achievable but loiter/low-speed operation (probably 60% of the operational profile) is difficult to address without taking considerable pitch off the propellers to meet the minimum diesel rpm. This leads to poor overall efficiency and a heavy maintenance burden with a large number of cylinders always in operation. Sequential Turbo Charging (STC) will still be required in twin diesel engine arrangements as a trail-shaft mode is routinely adopted at loiter and low speeds, exacerbating the efficiency problem further due to the additional ship resistance associated with trailing a shaft, maybe up to 20%.

A hybrid-electric system avoids many of the drawbacks of both systems described above. Configuring for twin diesels (say 8MW each) but including two small geared-electric motors of, say, 750kW each, leads to a system better optimised for the naval operating profile: loiter is taken care of by driving both shafts at maximum efficiency with the electric motors, powered by mildly up-rated ship service generators. Transit is either on twin diesels or on one diesel and one electric motor, thereby using ‘sided-boost’ to avoid trail-shaft losses, sprint is on both main diesels.

Figure 8 shows schematics of the systems.

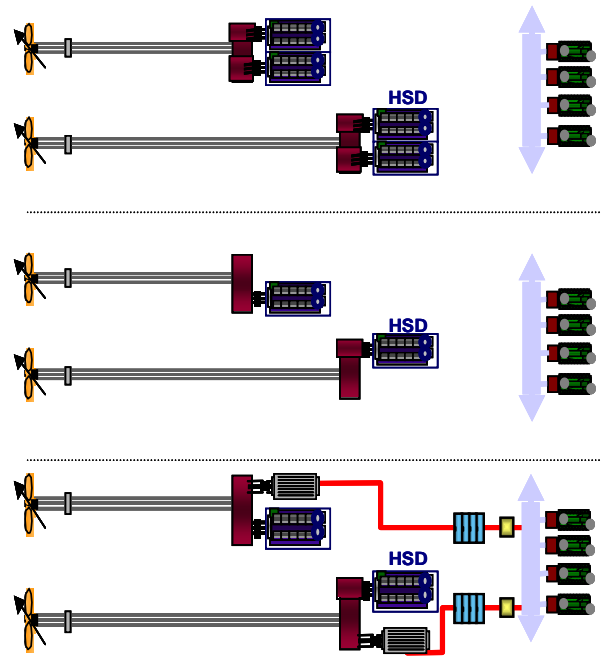

Figure 8 - Ocean Capable Patrol Craft 25 kt propulsion options

A comparison of diesel cylinder-hours between the twin diesel only and the hybrid-electric systems for a 2,000t vessel with 750kW electric motors shows a reduction of some 15%. More significantly it is the maintenance intensive low-power cylinder hours that can be avoided entirely, as the electric motors cover all low-speed / low-rpm operations.

Achieving a sprint speed of 28 or maybe 30knots or beyond is much more difficult with the 90m Ocean Capable Patrol Craft. The typical OCPC ship length hits the main resistance ‘trough’ at about 22 knots and the main resistance ‘hump’ at about 30 knots (Froude number of 0.31 to 0.54) and hence these ships are generally designed for service speeds nearer to 25 knots. Achieving 25 knots might require a propulsion power of about 18MW whereas achieving 30 knots in the same hull-form will require around 25 to 30 MW.

For the faster OCPC, the latest improvements to smaller high-speed diesels may once again open up the possibility of gas turbines in this ship type. Low cost, fuel-efficient and compact high-speed diesels (@ 1800 - 2100rpm) are now available up to 4.3MW and at this power the OCPC is able to achieve an endurance speed of around 20 knots. More general acceptance of multi-speed combining gears allows twin gas turbines at 12 MW each to be added to the small high-speed diesels thereby delivering maximum powers of around 30MW. Such a system

delivers very low installation impact with high un-refuelled endurance at a competitive cost. System options for CODAD and CODAG are shown in Figure 10, typical fuel usage at Figure 11 and initial weight and cost comparisons at Figure 12

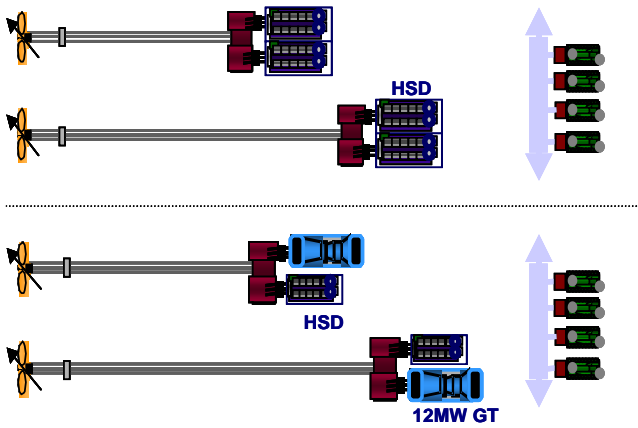

Figure 10 – Propulsion system configurations for the faster OCPC

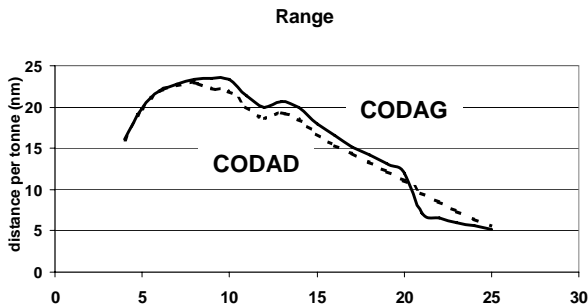

Figure 11 – Unrefuelled endurance comparison

As well as operational requirements, it is perhaps the propulsion challenge that is encouraging the move to faster vessels operating beyond the main propulsion hump and propelled by waterjets. The Swedish Visby and the Omani Baynunnah are both capable of speeds greater than 35 knots and are demonstrating the characteristics required for 21st Century warfare; both are waterjet powered and Visby is gas-turbine powered. These vessels are not trans-oceanic like the US Littoral Combat Ship and don't have the modular combat system. Instead they are very much configured as a faster OCPC type vessel performing the same roles as an OCPC but with higher maximum speed, greater manoeuvrability and are better optimised for the littoral theatre.

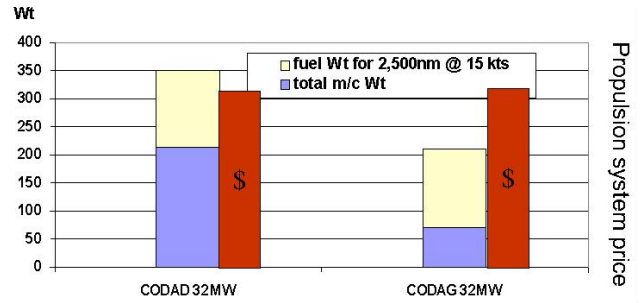

Figure 12 – Initial system weight and cost comparison for the faster Ocean Capable Patrol Craft

FAST COMBATANTS

The emergence of new threats and adoption of waterjets and gas turbines has seen a new class of littoral vessels being developed. In many respects the first of this new breed was the Swedish 'Visby' class. This is a relatively small vessel (approx 70m), designed to be deployed in a country's own littorals. High sprint speed, shallow draft, extended low-speed running, low noise and low magnetic signature are key characteristics but green-water capability, organic aviation and very high un-refuelled endurance are not attainable in a ship of this size.

The US Littoral Combat ship marks the other end of the fast littoral combatant being a larger transoceanic littoral ship with organic aviation and reconfigurable mission systems.

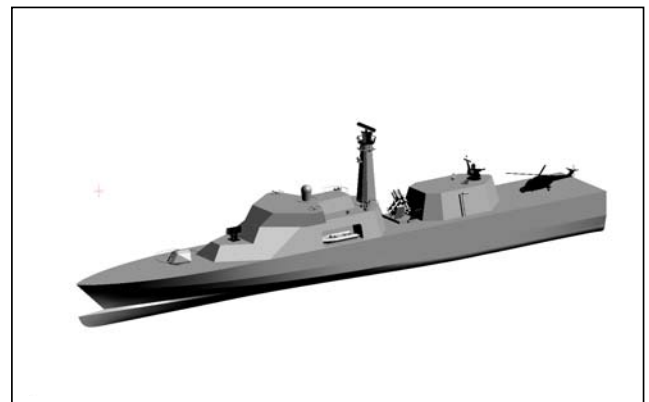

Figure 9 – Illustrative fast combatant developed to compare power and propulsion options for a high-speed green-water combatant

Somewhere between these two littoral combatants is likely to be a new class of fast green-water vessels capable of dominating the world's trade 'pinch-points' where speed, agility and endurance combined are required. This section looks at the power and propulsion options for such a craft. For the purposes of power and propulsion system options comparison a target green-water ship displacement of 2,500t has been used and the fuel load and mission systems were kept common. The fast littoral craft design developed is illustrated in Figure 9.

Propulsion options considered are shown in the following four figures.

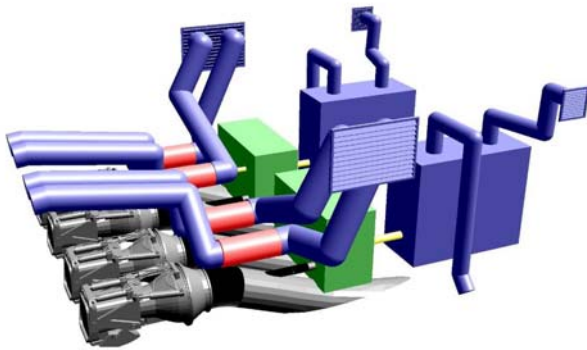

Figure 10 - an innovative Visby-style quad mid-size gas turbine and twin small diesel configuration - this arrangement leads to the smallest and lightest ship design with excellent maximum speed and endurance

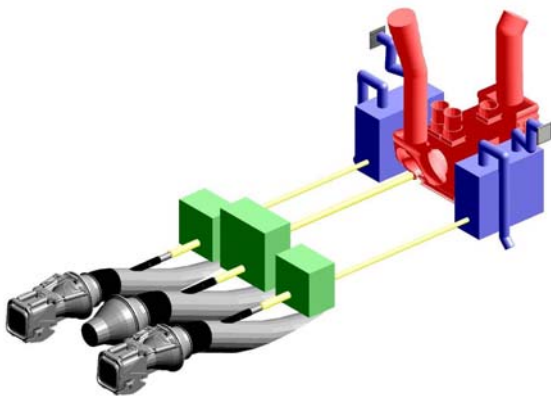

Figure 11 - showing a single gas turbine and twin diesel CODAG configuration.

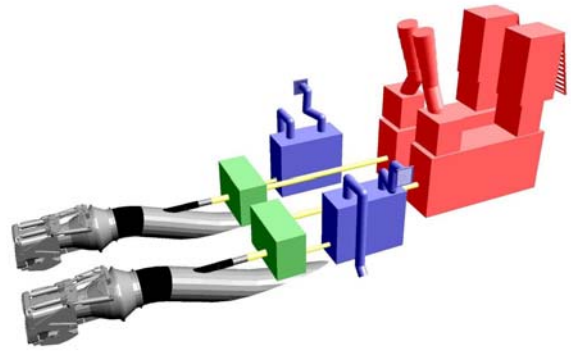

Figure 12 - showing a twin gas turbine CODOG arrangement

An all-electric power and propulsion system has a significant impact on the ship's general arrangement, structural and machinery weight and on unrefuelled endurance because of the significantly larger ship demanded by the space and weight required.

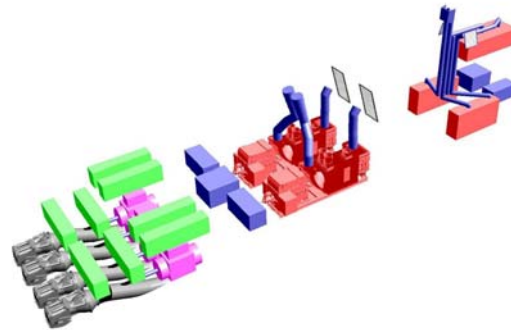

Figure 13 - all-electric or Integrated Full Electric Propulsion (IFEP) power and propulsion system arrangement

A ship and system weight comparison is shown in Figure 14. The Visby-style propulsion system can be seen as the lightest in weight and also has the lightest ship structural weight. The all-electric power and propulsion system is the heaviest by quite some margin as well as incurring the heaviest structural weight. The choice and availability of a particular power and size of gas turbine can have a significant impact in overall ship size and displacement.

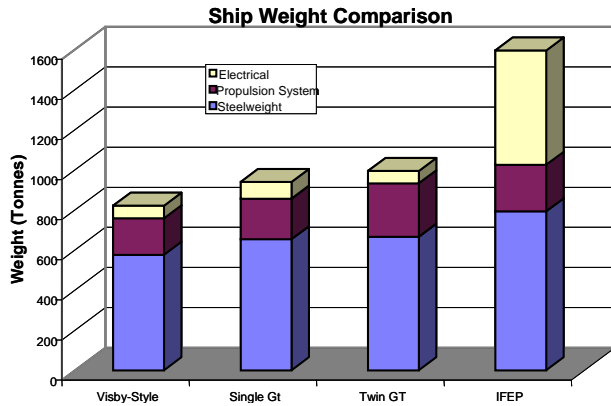

Figure 14 – Weight comparison between different power and propulsion options

A scale comparison of the three fast ship types can be seen in Figure 15 showing the 10m increase in ship length when going from Visby-style to conventional gas turbine and an further 10m again when adopting all-electric.

The Visby-style arrangement gains considerable benefit from the cold-end drive arrangements and exhausting over the stern allowing a smaller ship overall and by trading off the poorer fuel consumption of a smaller gas turbine against the smaller and lighter ship and its lower power requirement. The all-electric ship with gas turbine alternators demands a considerably larger ship to cope with the size of the electrical motors and the size and weight of the generation and transmission systems. Range is significantly curtailed due to the poor overall transmission efficiency.

Between the more conventional single and twin gas turbine arrangements, the single gas turbine gains benefit from the narrower beam of the ship allowing for a higher maximum speed. Table 1 shows the power and propulsion system comparison at a ship level.

The ‘small’ cold-end drive gas turbine is assumed fitted as ‘un-packaged’ as with Visby and other similar ships. Power density is very high with a unit weight less than 2t. No such engine is currently available for such a system, but the basis exists for a marine version of a current regional jet aero-gas turbine.

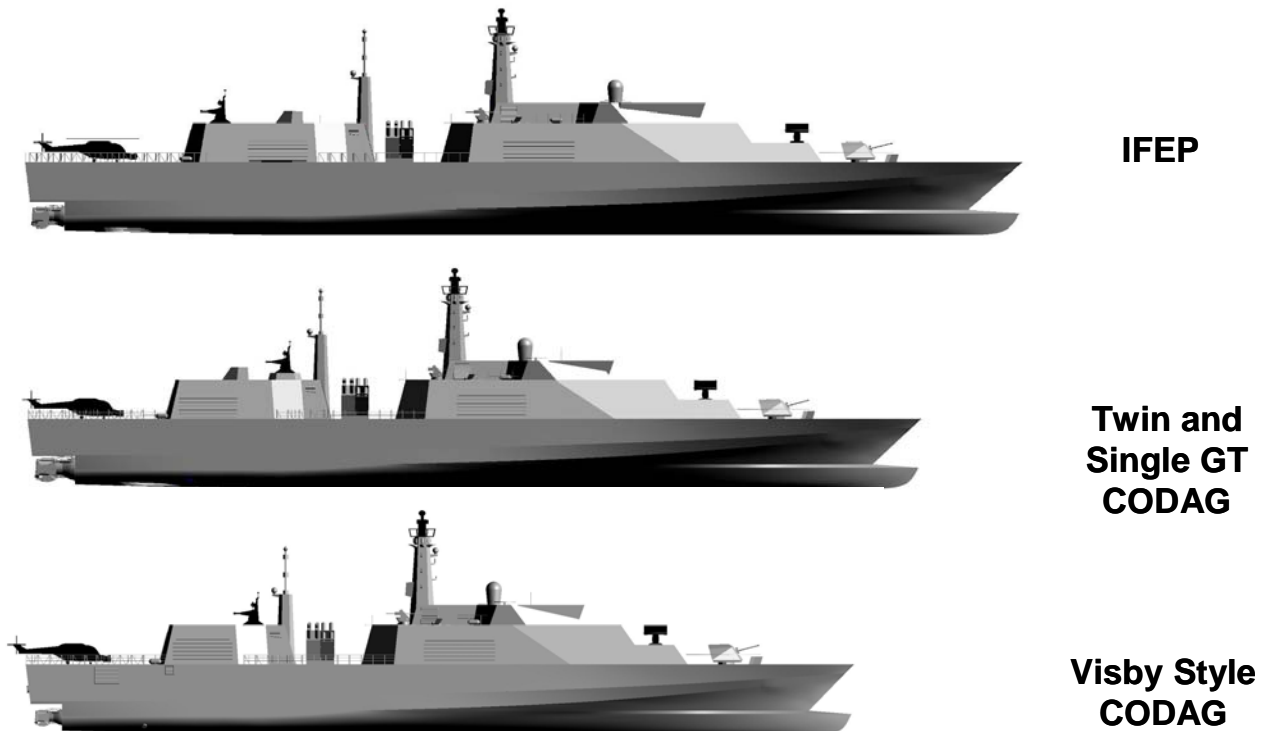

Figure 15 – Comparison of the ‘same mission’ fast littoral ship when comparing different power and propulsion options. The quad lightweight, cold-end drive gas turbine/diesel combination delivers an overall smaller and lighter ship with long unrefuelled endurance and high maximum speed

The Visby-style arrangement benefits from excellent fuel consumption throughout the ship speed range.

Characteristics of the gas turbine alternator (GTA) suitable for adoption in an all-electric version of the green-water fast combatant are dominated by the space available in a ship of this size: a key driver for such a GTA is its overall length which must not be much over 10m including package and alternator if it is to fit between an acceptable damage compartment length. [3]

Conclusions

Across the three ship types described there are distinct benefits for naval vessels in adopting optimised propulsion systems to match the latest gas turbine, diesel and electric technologies. Combinations of these lead to systems better matched to a combatant's operational profile. For blue-water operations, higher power gas turbines allow the matching of medium-speed cruise diesels or hybrid electrics with obvious operational benefits. For green-water operations higher-power diesels allow the matching of loiter electric drives better suiting the OCPC role and reducing through-life costs or for faster green water vessels a better matched gas turbine/diesel combination enabling the power density necessary to attain significantly higher speeds at similar initial cost levels. Where high-speed craft are required, waterjets change the dynamic of the design avoiding shaft rake and allowing compact but powerful gas turbines coupled with small high-speed diesels to reduce the size and cost of the ship.

REFERENCES

- [1] Bricknell, David J and Skarda, Robert - Power Growth in Naval Combatants, DTA Asia Feb 2005
- [2] Bricknell, David J and Partridge, Richard – Power and Propulsion for the Modern Global Combatant; Pacific 2006
- [3] Casson, Wood, Bricknell, Daffey, Partridge – Power and Propulsion for the new global combatant; RINA Warship 2006

© Rolls-Royce plc